

~ 220-240 V 50/60 Hz

+5°C

IS500

IS1600

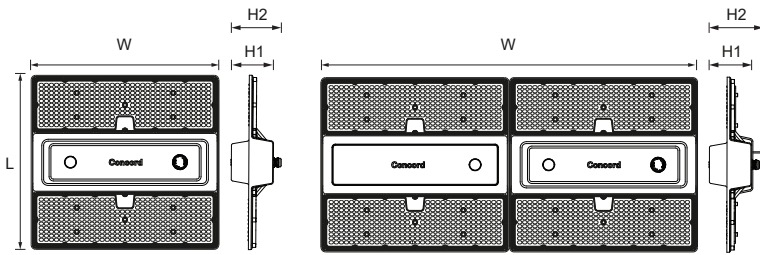

a
9/13/20/26/32 klm

b
40/52klm

	L [mm]	W [mm]	H1 [mm]	H2 [mm]	Kg	ta [°C]
10.000 lm	446	481	108	128	<5.0	+5
9.700 lm						+35
14.200 lm	446	481	108	128	<5.0	+5
13.800 lm						+35
22.000 lm	446	481	108	128	<5.0	+5
21.300 lm						+35
27.800 lm	446	481	108	128	<5.0	+5
26.900 lm						+35
34.600 lm	446	481	108	128	<5.0	+5
33.500 lm						+35
44.000 lm	446	963	108	138	<11.0	+5
42.600 lm						+35
55.500 lm	446	963	108	138	<11.0	+5
53.800 lm						+35

The luminaire is suitable for use in environments where an accumulation of conductive dust on the luminaire may be expected.

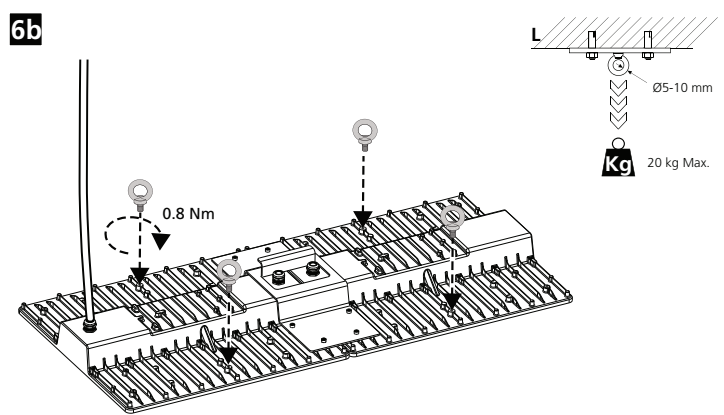
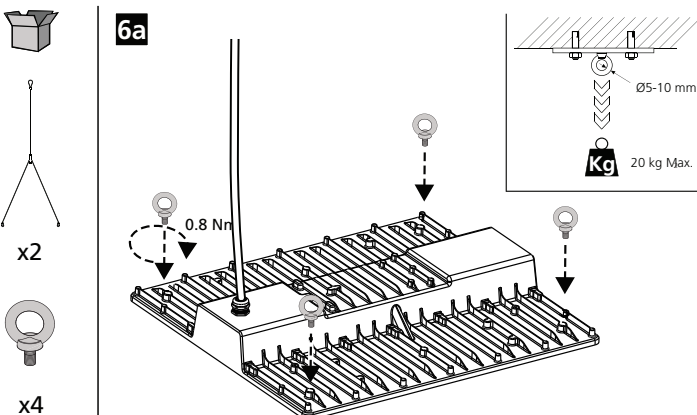
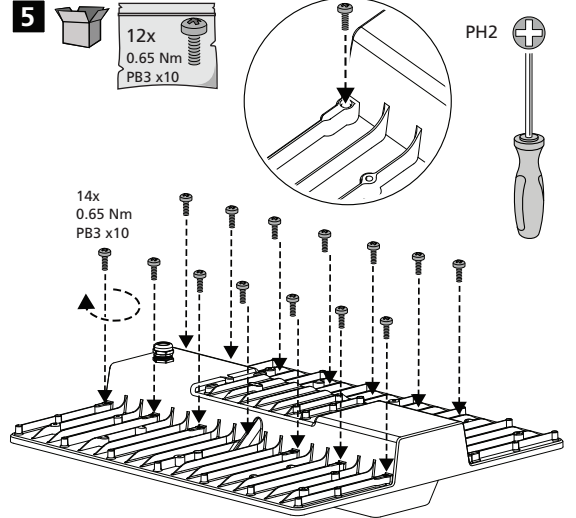
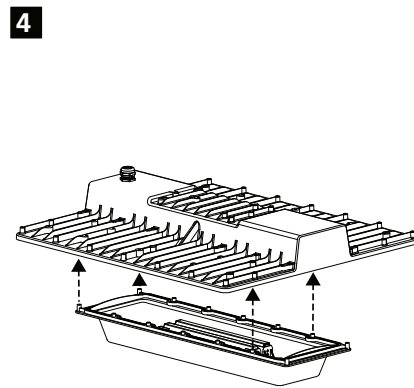
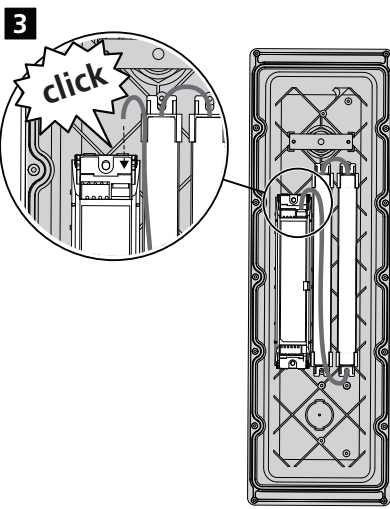
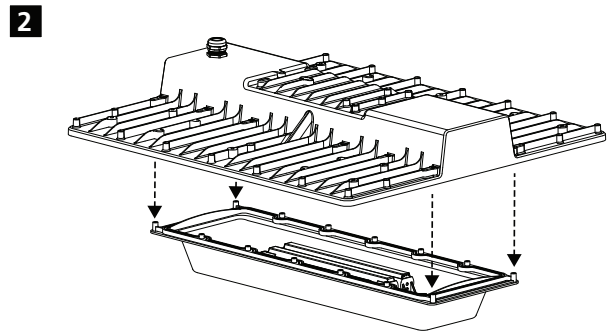
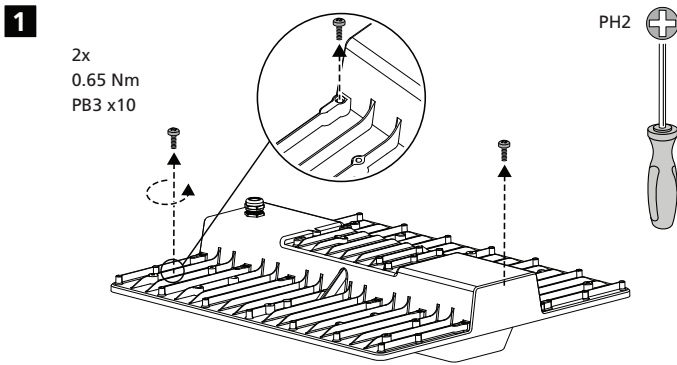

7

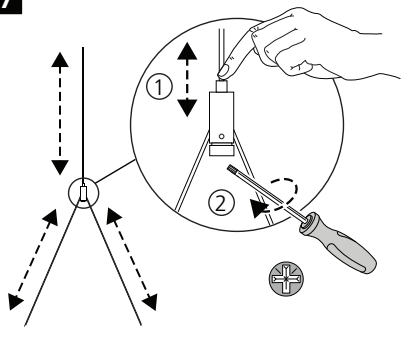

8a

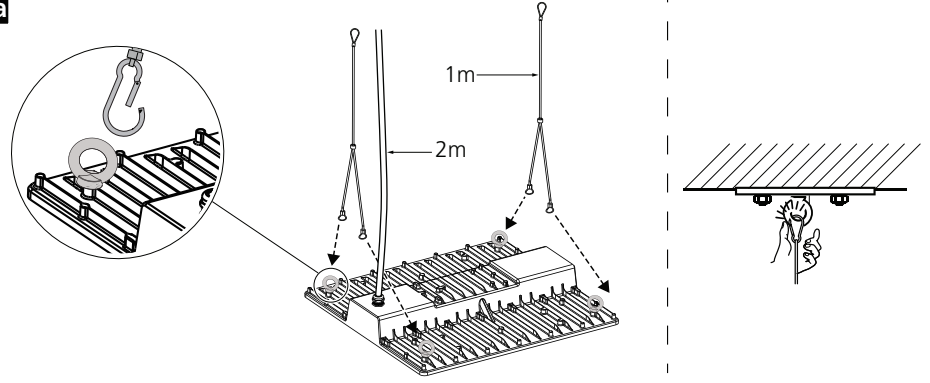

8b

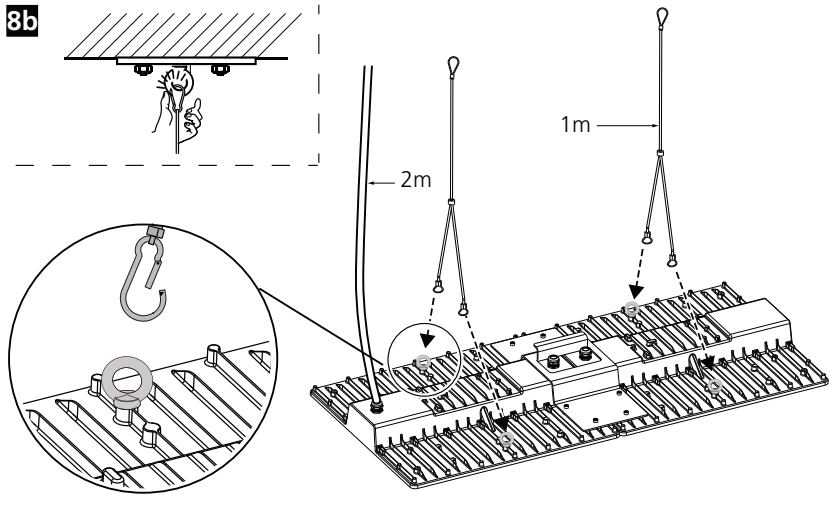

9a

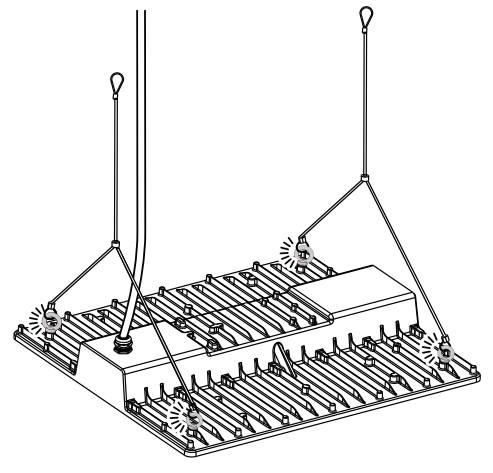

9b

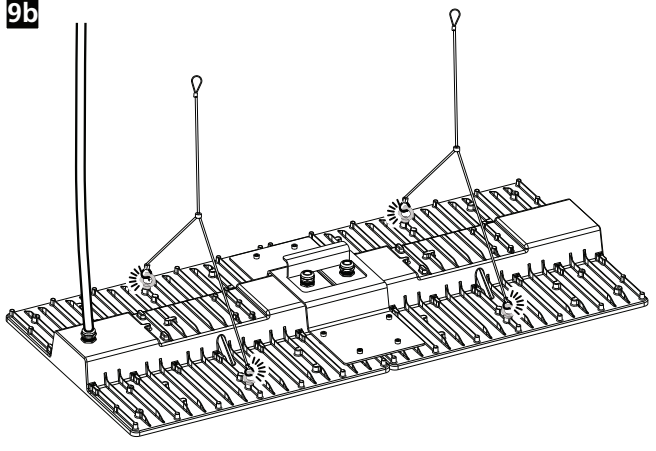

10a

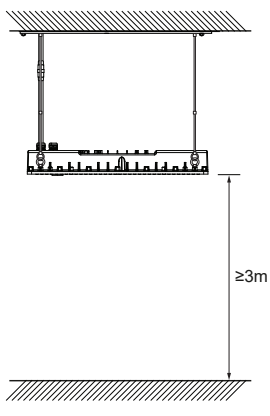

10b

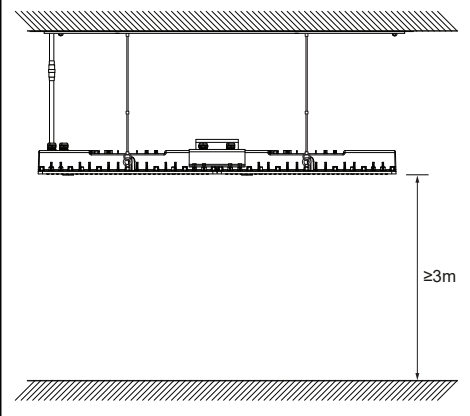

11 ⚡ 230-240V + ⚡

Min. 600V AC / 5A, IP65

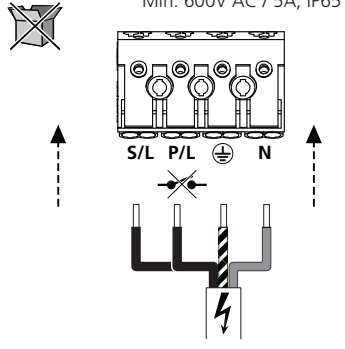

i ⚡

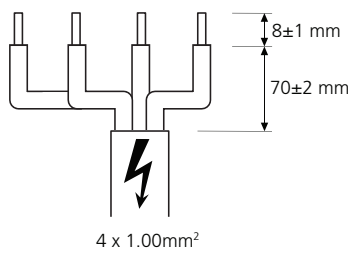

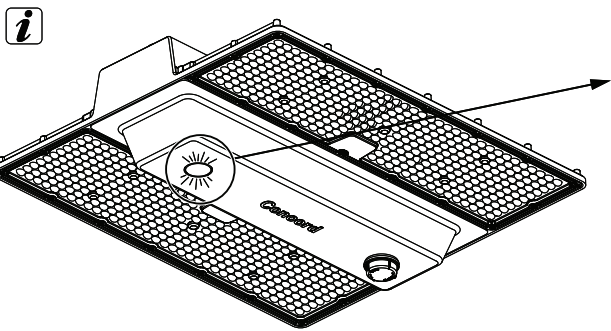
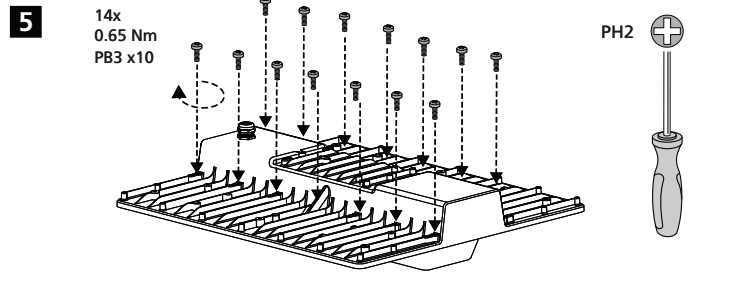
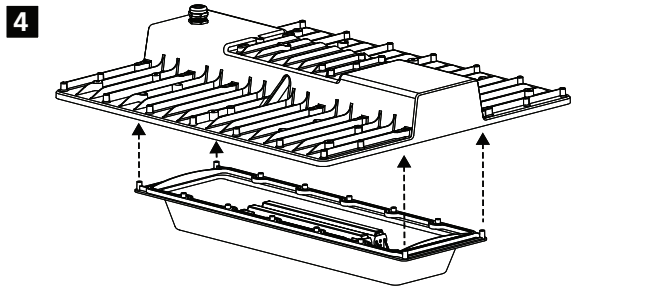
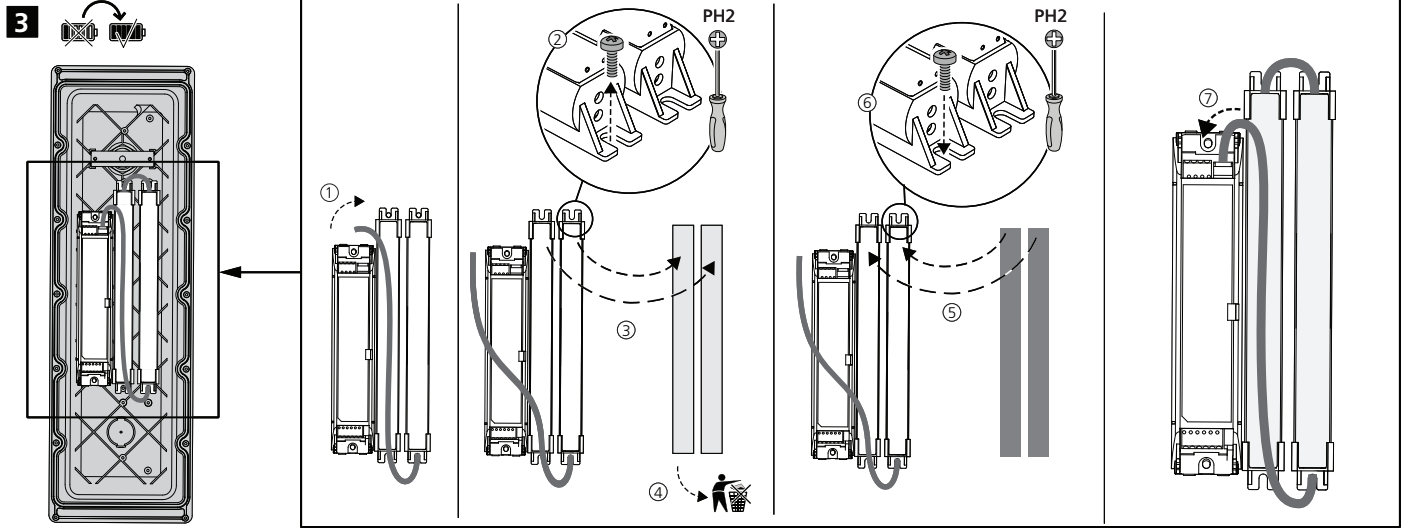
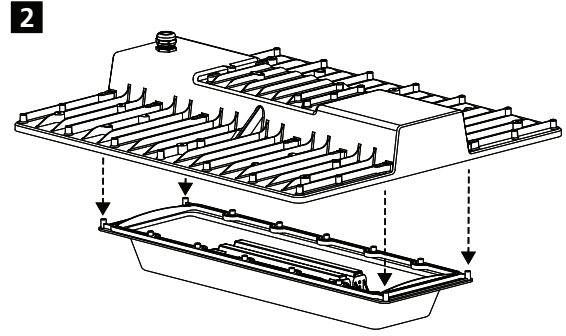
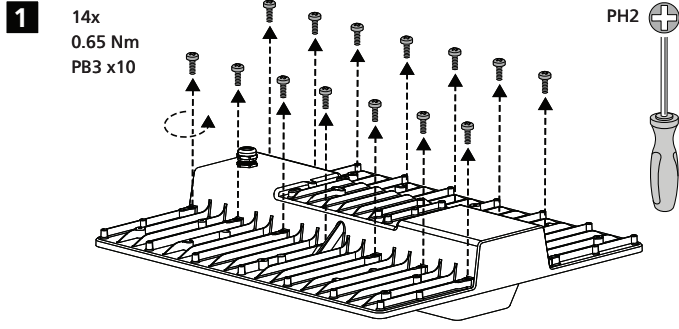

LED Colour	LED Indication	STATUS		COMMENT
		Status	Flashing	
Green	●	∞	-	Battery Connected and Charging
	●	0.1 sec	0.1 sec	Functional Test in Progress
	●	1 sec	1 sec	Duration Test in Progress
Red	●	∞	-	Load Failure
	●	1.0 sec	1.0 sec	Battery Failure
	●	0.1 sec	0.1 sec	Charging Failure
Red&Green	●	-	∞	DC (Emergency) Mode

i

TRIDONIC
 Faerbergasse 15
 6851 Dornbirn / Austria
 Accu-LiFePO₄ 9.0Ah 6C CON
 Art. No: 28002330
 Lithium Iron Phosphate Battery
6 Cell 3.2 V
9.0Ah 28.8Wh
 11FpR19/66-6

02-24
Date of Manufacture

Max. continuous cell case temp refer to control gear data sheet

Li

Date of installation:

Y-type



Z18 + PIR

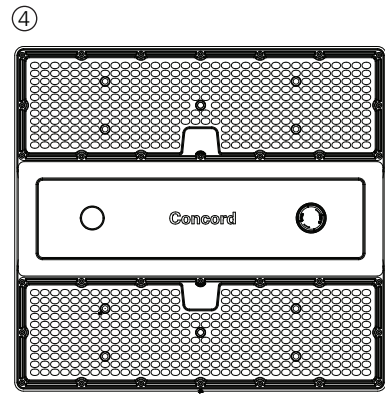
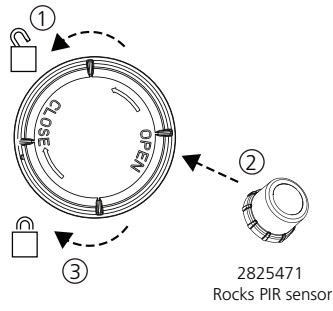
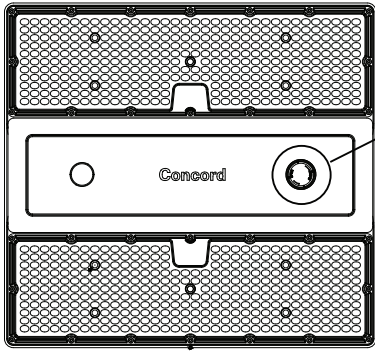

! 25/50/75/100%

⊗ 25%

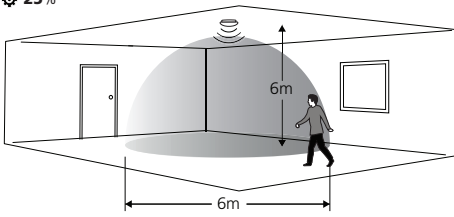

⊗ 50%

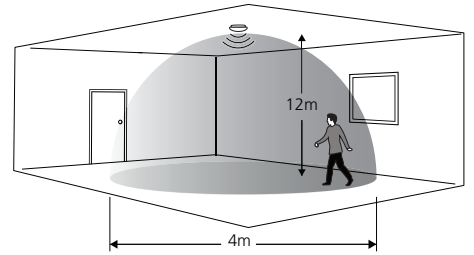
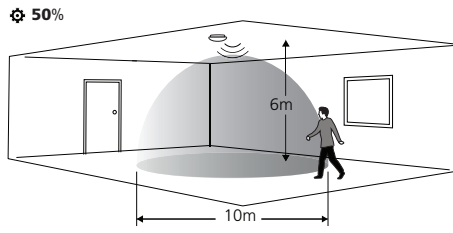

⊗ 75%

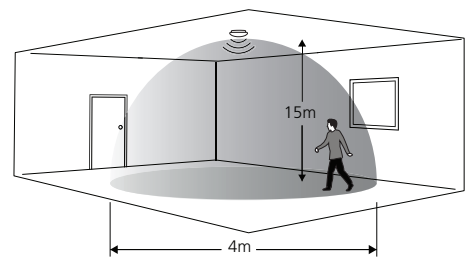
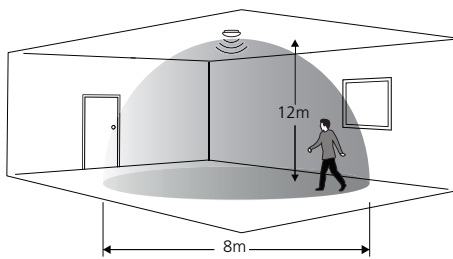
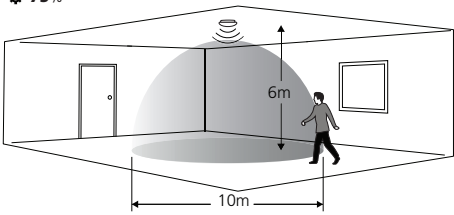

⊗ 100%

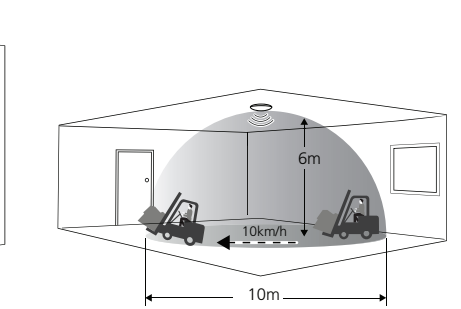
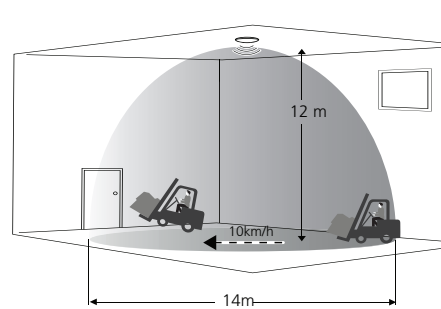
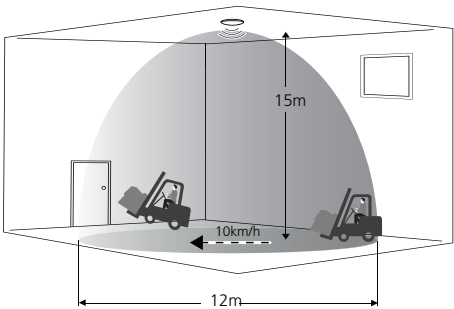
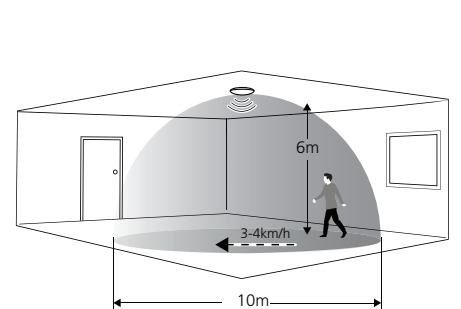
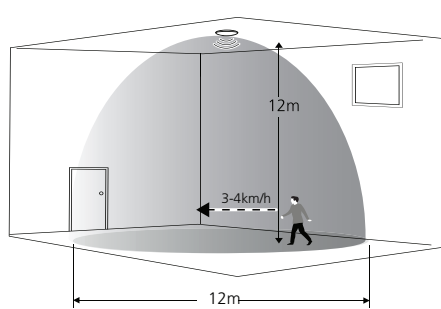
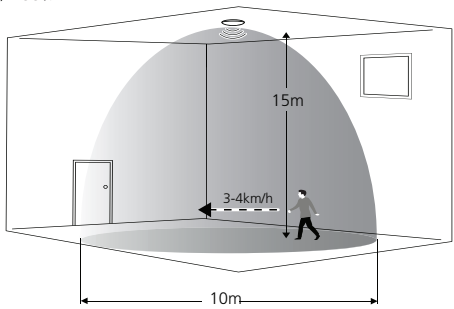

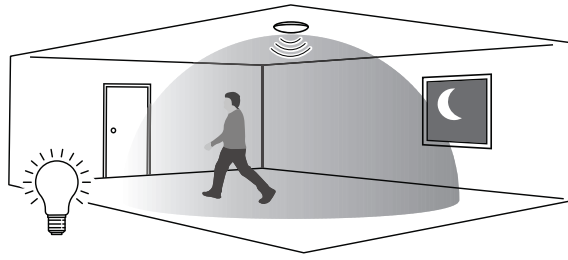
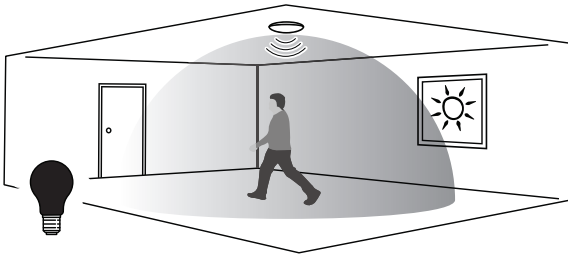

Daylight threshold (⚙️ disable)

100 Lux / 150 Lux / 200 Lux / 300 Lux /
400 Lux / 500 Lux / 1000 Lux / Disable

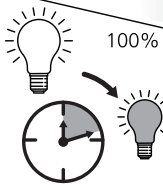
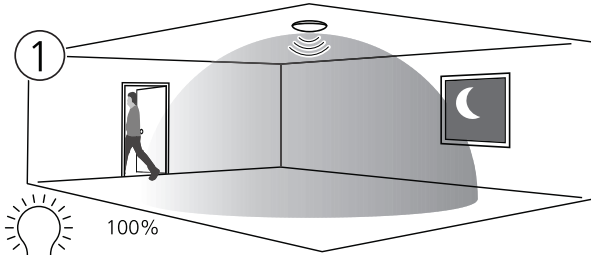

100%

Stand-by dimming level (⚙️ 10%)

0% / 10% / 30% / 50%

Hold-time (⚙️ 10min)

Test 3s / 30s / 90s / 5min / 10min / 30min

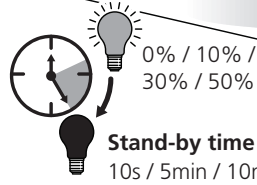
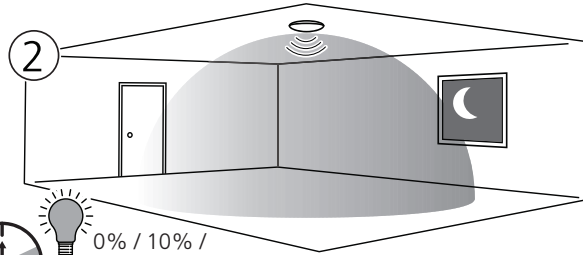

0% / 10% /
30% / 50%

Stand-by time (⚙️ 10min)

10s / 5min / 10min / 30min / 1h / ∞

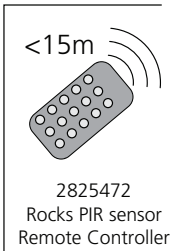

2825472
Rocks PIR sensor
Remote Controller

Z18 + SylSmart® Connected

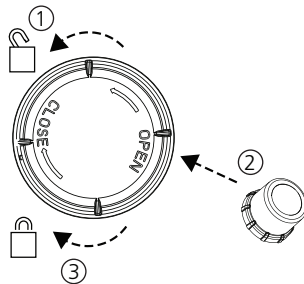
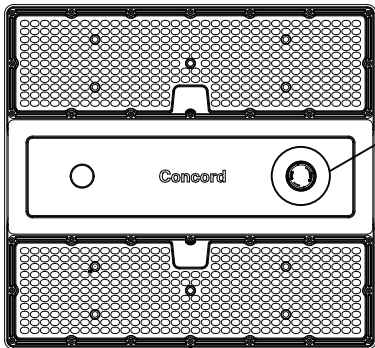

V970020 SylSmart® Connected (SSA)
Sensor version

V970021 SylSmart® Connected (SSA)
Control Node version

